



Weyn-Lauwers N.V.

Industriepark-Noord 12
B - 9100 SINT-NIKLAAS

Tel. : 00 32 (0)3 776.34.13
Fax : 00 32 (0)3 778.09.52
weynlauwers@weynlauwers.be
www.weynlauwers.be

**GATE VALVE
DUCTILE IRON - PN16
FIG 342**

DESIGN FEATURES

- ductile iron gate valve dn40 - dn300 PN16
- temp : -10°C +120°C
- specifications :
 - rising stainless steel stem
 - non-rising handwheel
 - brass seat
 - single wedge disc
 - leakage rate B acc. to EN 12266-1

USE

- for all common fluids
- max. pressure : up to 16 bar

MATERIALS

item	Part name	Material
1	body	ductile iron EN-GJS-500-7
2	body seat	brass
3	wedge	ductile iron EN-GJS-500-7
4	wedge seat	brass
5	stem	SS420
6	screw	steel RSt37-2 (1.0038)
7	nut	steel RSt37-2 (1.0038)
8	nut	steel RSt37-2 (1.0038)
9	bonnet	ductile iron EN-GJS-500-7
10	packing	graphite
11	packing gland	ductile iron EN-GJS-500-7
12	nut	steel RSt37-2 (1.0038)
13	screw	steel RSt37-2 (1.0038)
14	sem nut	brass
15	washer	brass
16	handwheel	cast iron EN GJL-250
17	handwheel nut	ductile iron EN-GJS-500-7

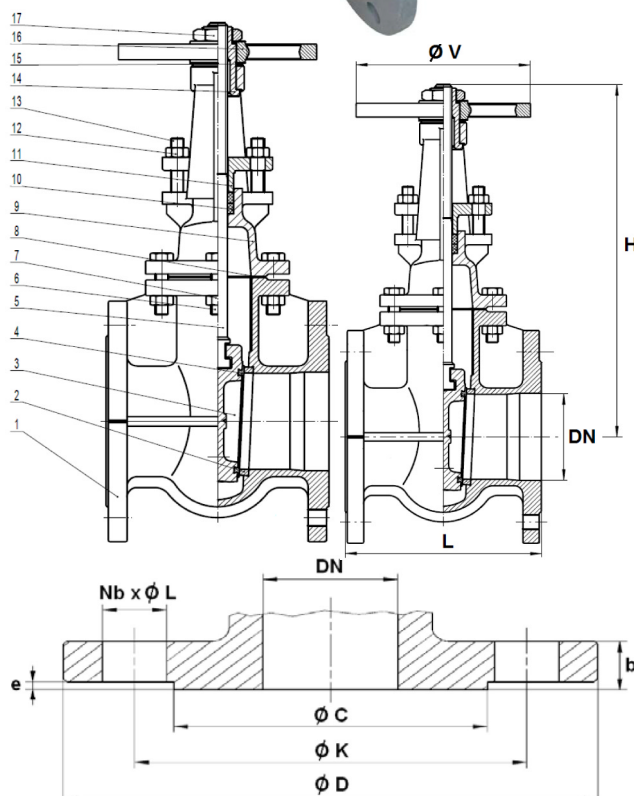

SIZE (in mm)

DN	40	50	65	80	100	125	150	200	250	300
L	140	150	170	180	190	200	210	230	250	270
H(closed)	244	254	294	331	385	457	545	683	823	952
H(open)	295	315	371	424	500	598	711	901	1093	1273
V	160	160	160	160	200	200	250	250	320	320
C	80	102	124	140	158	188	212	268	320	370
D	150	165	185	200	220	250	285	340	405	460
K	110	125	145	160	180	210	240	295	355	410
Nb x L	4x19	4x19	4x19	8x19	8x19	8x19	8x23	12x23	12x28	12x28
b	16	16	16	17	17	18	20	21	23	24
e	2	2	2	2	2	3	3	3	3	4
kg	9,8	11,9	13,3	17,2	23,2	34,2	44,4	67,5	110	155
ref.	342.08	342.09	342.10	342.11	342.12	342.13	342.14	342.16	342.18	342.20